

# ARITERM



INSTALLATION, OPERATION AND MAINTENANCE

→ Biomatic 50



## ■ CONTENTS

Important Information.....	2
Dimensions / Items included.....	3
Operating Principle.....	4
Wiring Diagram.....	5
Control Panel .....	6
Installation.....	6
Water Piping .....	7
Filling of Water .....	8
Maintenance, Care, Sweeping.....	8
Advice about Fuel Pellets .....	9
Pellets Store.....	9
Guarantee.....	10
Declaration of Conformity.....	10
Installation Protocol.....	11

## ■ IMPORTANT INFORMATION

- ✦ Keep this instruction manual readily available for future use.
- ✦ Read the instructions carefully before taking your boiler into service.
- ✦ Follow these instructions carefully and carry out care and maintenance work as recommended.

### ■ Notification to building authority

Attention! When you change heating installation this must always be communicated to the local building authorities.

### ■ Sweeping

According to the fire protection laws a chimney shall be swept regularly. This is done by the local chimneysweep. Sweeping of the boiler shall be carried out in such a manner that good operating economy is achieved. (see under "Maintenance") Prepare to chimney-sweeping by turning off the boiler at least one hour before cleaning to minimize the amount of glowing ash.

### ■ Maintenance contract

Ariterm recommends the boiler installation to be made by a company with professional competence. For more information please contact your Ariterm retailer.

### ■ Replacing of spare parts

Ariterm recommends that replacing of spare parts is made by authorized serviceman of Ariterm retailer. The retailer supplies required spare parts and authorized serviceman makes the necessary adjustments and combustion gas analysis when replacing spare parts.

## DIMENSIONS / ITEMS INCLUDED IN THE DELIVERY

Art.nr

Biomatic 50 (art.nr PELL-517010050)

### Standard delivery

- Sweeping gear

### Accessories

- Combination flue for horizontal and vertical installation (art.nr 5208)
- Hot water heat exchanger
- Assembly kit for oil burner

#### TECHNICAL SPECIFICATION

<b>Performance</b>	Capacity range, pellets	25 - 50 kW
<b>Dimensions</b>	Width Depth (without flue pipe) Height (without connections) Weight Water contents	606 mm 720 mm 1690 mm 452 kg 115 l
<b>Design values and settings</b>	Design pressure Design temperature Recommended flue gas temperature Recommended draught Rec. free height above boiler	0,5 - 1,5 bar max 100 °C 100 - 140 °C 5-20 Pa 500 mm
<b>Connections</b>	Heating system Expansion Drain Flue	DN 25 / 50 DN 25 male thread DN 15 Ø 139 mm

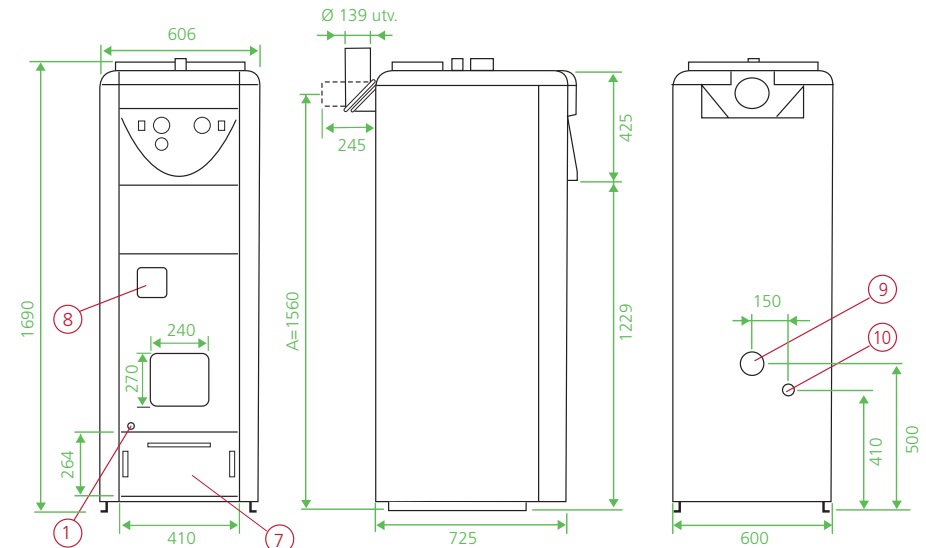

Dimensions are without adjustable feet

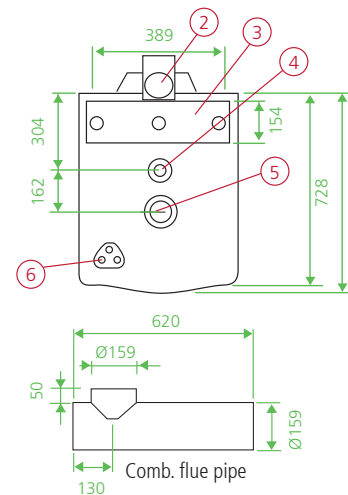

A-dimensions including comb.flue pipe is app. 1853 mm

### Biomatic 50

1. Drain DN 15
2. Flue pipe Ø 139 mm
3. Sweeping hatch
4. Expansion DN 25 male
5. Feed line DN 50 male
6. Cable bushing
7. Ash box
8. Sight glass
9. Return line DN 50 male
10. Return line DN 25 male

## ■ OPERATING PRINCIPLE

Biomatic 50 the new generation pellet boiler is specially designed for pellet heating. It is equipped with vertical convection tubes to prevent soot to stick to the convection surfaces.

Biomatic 50 is equipped with an oversized ash box to facilitate maintenance work. Sweeping is mainly done from the soot-hatch on top of the boiler but also through the rebox door where the burner is located. The boiler is designed to operate with a pellet burner.

Biomatic 50 consists of a combustion chamber with flue pipes, which is enclosed by a jacket holding 115 litres of water. Heat generated by the burner is transferred directly to the boiler water.

### ■ Oil heating

The Ariterm pellet boiler can also be used for heating with oil (oil heating accessories on demand).

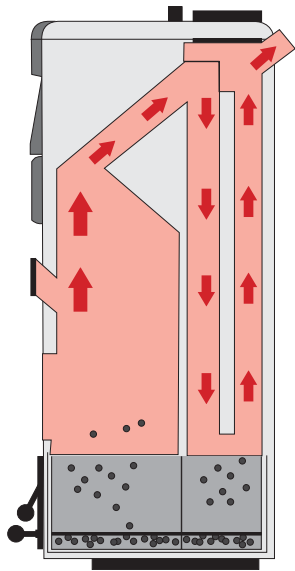

## WIRING DIAGRAM

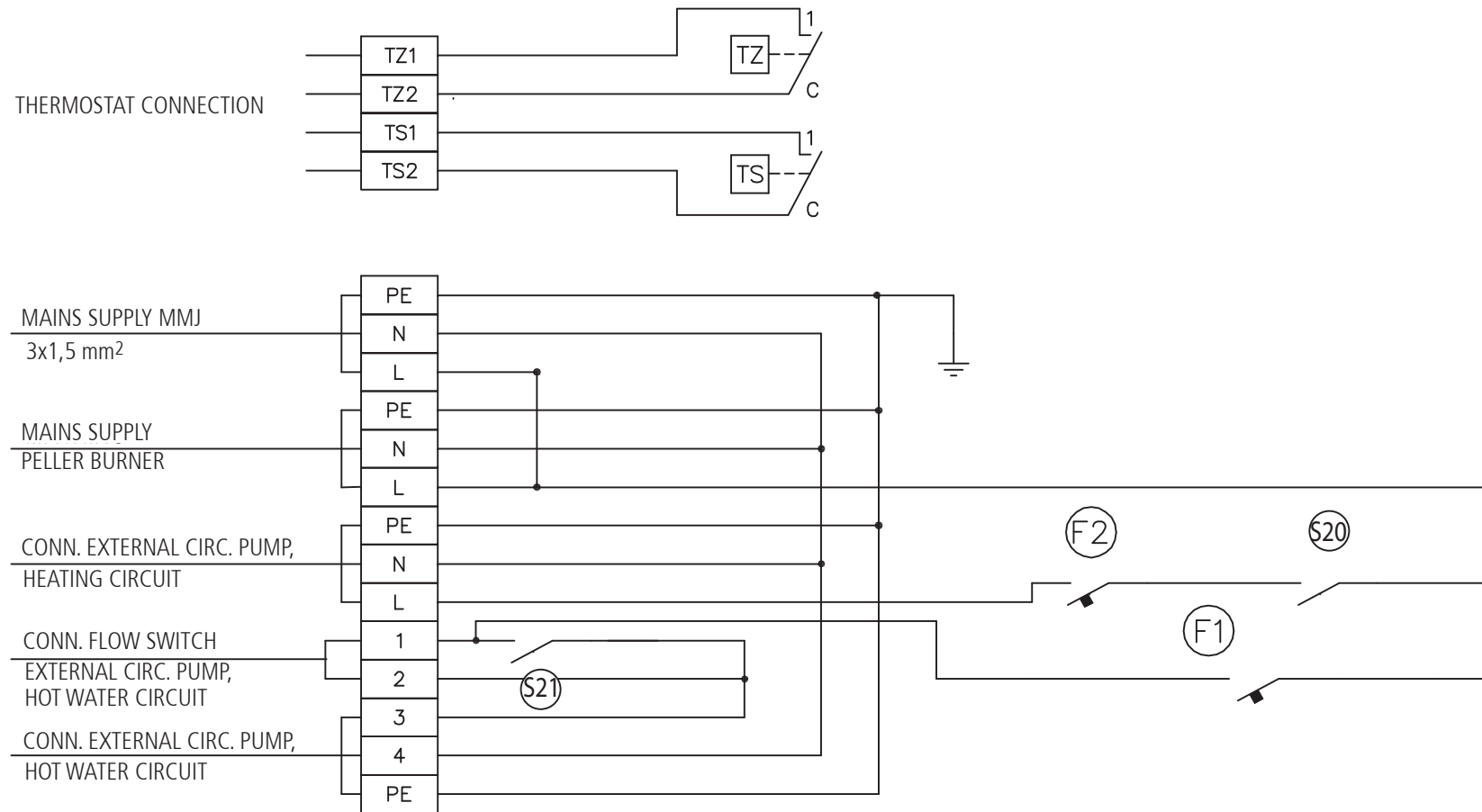

- F1 Control fuse 3 A, external circ. pump hot water circuit
- F2 Control fuse 3 A, external circ. pump heating circuit
- S20 Switch, external circ. pump, heating circuit On/Off
- S21 Switch, internal circ. pump, hot water circuit, continuous operation
- TS Regulating thermostat, burner
- TZ High limit thermostat, burner

## ■ CONTROL PANEL

1. Regulating thermostat  
Adjustment of operating temperature for pellet burner
2. Overheating protection, burner  
- Press the button to reset the overheating cut-out. Before reset, check that there is water in the boiler and that the operating thermostat works correctly. If you cannot reset the overheat protection, please contact a qualified installation contractor.
3. Thermometer / Pressure gauge  
- Shows water pressure and water temperature at the top of the boiler. Due to the stratification of water, boiler temperature varies considerably within the boiler; the lowest water temperature is measured at the bottom and the highest at the top.
4. Flue gas thermometer  
- Displays temperature of leaving flue gases at the flue connection point.
5. Automatic fuse  
- Automatic fuse, circulation pump, external heating circuit.
6. Switch  
- Switch, circulation pump, external heating circuit.
7. Automatic fuse  
- Automatic fuse, circulation pump, external hot water circuit.
8. Switch  
- Switch, circulation pump, external hot water circuit.
9. Connection for external auger

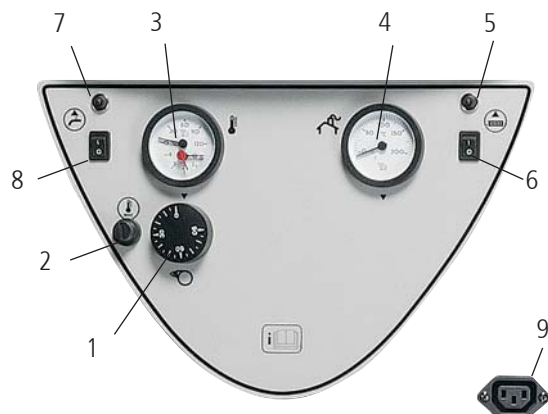

## ■ INSTALLATION

The boiler shall be positioned and installed according to the building rules in force. Before installing the boiler, the chimney must be controlled for underpressure and possible risk of condensation. It is possible that an air draught compensator has to be installed. Inner pipe is recommended for minimizing the risk of condensation. Space needed for installation: Minimum clearance in front of the boiler (burner included) is 1000 mm. Clearance on the top shall be at least 0,5 m. By the other side of the boiler clearance shall be at least 0,8 m. The boiler must be level. If the floor is uneven, adjustments can be made with the help of four adjusting bolts (enclosed with the boiler) that shall be fitted to the bottom plate of the boiler. The air intake duct to the boiler room must have at least the same area as the flues.

### ■ Chimney installation

To embed the angular tube in the chimney, proceed according to the drawing below. If the tube is embedded as described, you will be able to avoid soot leakage when the chimney is being swept.

### ■ Flue connection and combustion air intake

The combination flue of the boiler allows for connection towards the top as well as to the rear. Boiler cement is suitable for sealing. Recommended flue gas requirements for Biomatic+ 50: brick chimney lined with a Ø 150 mm acid proof thin-walled tube or an acid proof Ø 150 mm element chimney. Recommended underpressure in the chimney is 25 Pa. The height of the gas flue shall be dimensioned according to the building's requirements, but should be at least 6 m. If condensation water comes out of the flue, a condensate drain pan shall be installed in the lower portion of the chimney. The combustion air intake must not be covered.

**ATTENTION!** The chimneysweep must be notified for inspection of the flue.

**CAUTION!** The boiler has low flue gas temperatures, which, under certain conditions, might lead to condensation of flue gases.

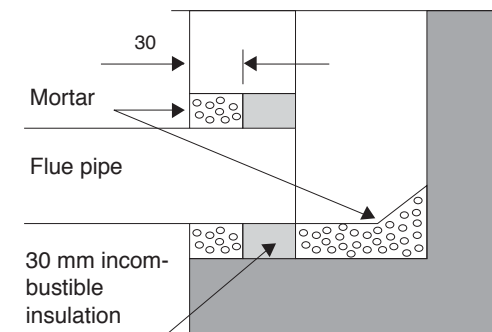

## ■ WATER PIPING

Water piping shall be carried out in accordance with current local and national hot water and building regulations. Safety equipment shall be installed in accordance with regulations in force. If a closed expansion vessel is used, an approved safety valve, a pressure gauge, and a vent valve shall be fitted. The safety valve shall be fitted just above, but not directly on, the boiler in such a manner that the connection with the boiler cannot be closed off. The connecting line from the boiler to the safety valve must rise continuously. Before the boiler is filled with water, the enclosed drain tap shall be fitted.

### ■ Radiator system and expansion vessel

When you fill the system, all valves must be open and the external circulation pump turned off. Bleed the system carefully while filling. When the installation has been in service for a few days, it shall be bled and refilled once again.

**ATTENTION!** See also separate instructions for filling of water.

The volume of the expansion vessel is determined as follows:

#### Open system:

5% of the water volume in the heating system.

#### Closed system:

Select the volume of the vessel in accordance with the manufacturer's instructions.

In the following table, you will find examples of suitable closed system expansion vessels.

System volume (litre)*	Opening pressure (bar)	Initial pressure (bar)	Vessel volume (litre)	
			70°C	90°C
500	1,5	0,5	35	80
1000	1,5	0,5	80	140
1500	1,5	0,5	80	140
2000	1,5	0,5	140	200

An open system with 500 litre water volume demands at least a 35 litre expansion vessel and a 1500 litre system volume a 80 litre expansion vessel

\* System volume = boiler volume + storage tanks + piping volume + radiator volume.

### ■ Planning and installation

Planning and installation shall be carried out in a professional manner, attention being paid to general and local rules and regulations. Operating pressure is max. 1,5 bar. Before taking the installation into service, and always at the beginning of the heating season, the following checks shall be carried out:

- + that the heating system is filled and bled
- + that the circulation pump is working
- + that the system valves are open
- + that the automatic control and safety devices are in working order
- + that the chimney has the necessary draught and that the fresh air ventilation is open.

### ■ Safety valve

If a closed expansion vessel has been installed in the radiator system, the safety valve must be checked 4 times a year. Activate the valve by pressing or turning the control button and check that water escapes from the overflow pipe connecting the valve to the drain.

## ■ FILLING OF WATER

Before you begin heating, the heating system must be filled with water.

To fill the system, do as follows:

1. Open all shut-off valves, including the shunt valve.  
The pump must be switched off.
2. Fill the boiler and the radiator system with water.  
Bleed the system at the radiators.
3. Once the system is filled completely, the circulation pump can be started and heating can begin.
4. When the boiler water has reached its pre-set operating temperature, the pump should be stopped and the system bled at the radiators once again. This should be repeated several times.

Remember that much air is enclosed in tap water. The enclosed air volume may reach as much as 10%, which explains why bleeding takes time – especially where there are large water volumes. A closed system shall be filled until the pressure gauge indicates the correct system pressure, i.e. the distance from the pressure gauge to the highest radiator in meter times 0,1 which gives the system pressure in bar. Adjust the red needle of the pressure gauge to the same value as the big needle.

## ■ MAINTENANCE, CARE, SWEEPING

### ■ Boiler cleaning

Burning solid fuels, even if operation is automated, normally calls for a little more care and maintenance than oil heating. For Biomatic 20 maintenance has been minimized as the result of well planned design and a big ash box holding 50 litres. Ash is removed when necessary. The convection parts of the boiler are to be cleaned when the flue gas temperature has risen by 20-30°C above the temperature of a newly swept boiler.

**ATTENTION!** Pay special attention to the pellets quality when you receive a new delivery or when you change supplier.

**ATTENTION!** Show a great care when emptying the ash as it might be glowing hot. Ash must be kept in a fireproof container.

The following measures and checks should be carried out when the boiler is cleaned:

- ♦ Switch off the burner an hour before service.
- ♦ Lift the soot hatch at the top of the boiler and brush clean the flues.
- ♦ Remove the fixing bolts from the burner and loosen the hose and electric connections.
- ♦ Pull out the burner and brush clean the walls of the combustion chamber.
- ♦ Empty the ash.

**ATTENTION!** Disconnect the power to the boiler before removing the protective housing

**ATTENTION!** Show great care when emptying the ash as it can be glowing hot.

## ADVICE ABOUT FUEL PELLETS

- Pellet fuel can be manufactured from several different biologically derived raw materials. Most common is wood, but today there are several alternative materials available on the market that are suitable for pellets manufacture. These raw materials have various characteristics that can be advantageous or disadvantageous for pelletised fuel.

Important factors that can be assessed are energy content, size, amount of fines, moisture content and, last but not least, the price. We recommend that you choose the fuel that has the lowest cost per energy unit after checking how the fuel performs in the burner. Study carefully the fuel performance after new delivery.

In case of doubt, please contact us at Ariterm.

- Most of the problems that arise on account of inferior fuel quality are the result of inadequate handling and storage before the fuel reaches the end customer. If the fuel has high fines content the problem is usually due to separation during storage or loading.

The formation of sintered ash is due to silicate contaminants (sand). These cannot be discovered before they are used. If you get pellets that produce sintered ash, a claim must immediately be sent to the pellet supplier.

**ATTENTION!** If sintered ash is formed, the burn pot must be continuously cleaned of sintered material (with a table spoon for example).

- Damp pellets can be the result of inadequate handling and transport. If possible, inspect the pellets before they are unloaded to make sure that you get clean and dry pellets and no fines.

**ATTENTION!** Damp pellets must be rejected immediately.

FUEL RECOMMENDATION	
Raw material	Chemically untreated barkless wood
Diameter	8 mm
Length	15 to 32 mm
Volume weight	over 600 kg/m <sup>3</sup>
Moisture content	less than 10 %
Ash content	less than 0.7 weight %
Fine material content	max 4 weight %
Melting temperature of ash	> 1100 °C
Energy content	>4,75 kWh/kg

## PELLET STORE

Thanks to the pellet feed system the pellet store can be built for bulk deliveries. The store can either be located inside the house or in a separate building. Pellets must, however, never be exposed to moisture.

### Data for flexible feed system:

Maximum climb: 2,5 m

Maximum gradient: 45°

Outside pipe diameter: 75 mm

**Attention!** The pellet store can have a maximum of 3 intake openings, and only one intake can be used at a time.

The store shall be well sealed to avoid the spreading of dust. As a guide when determining the size of the store, it may be useful to know that the minimum bulk delivery is normally 3 tons if you wish to avoid freight surcharge. 1 ton of pellets corresponds to about 1,6 m<sup>3</sup>. To accommodate 3 tons of pellets you would need a store of at least 6 m<sup>3</sup> to have some space to spare.

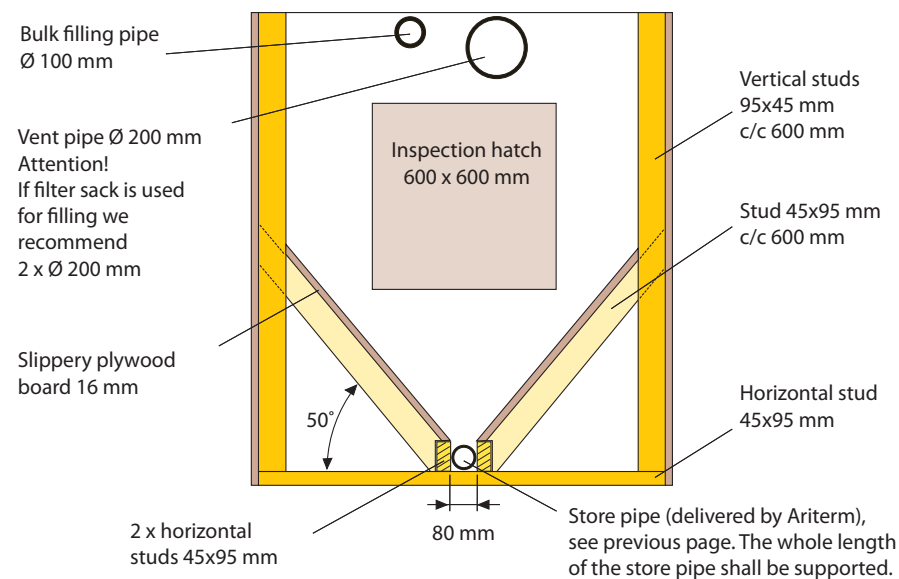

The drawing represents a stand alone pellet storage bin. If the store is built against a supporting wall, the sloping studs will have to be arranged differently.

## ■ GUARANTEE

This boiler manufactured by Ariterm AB is guaranteed to be free of defects in workmanship and materials for a period of 24 months (2 years) from the date of installation. The manufacturer shall not be held liable for faults caused by incorrect installation, incorrect use, freezing, over-temperature or over-pressure. Any attempts made to repair the product without the manufacturer's permission or if the guarantee card has not been returned to the manufacturer, will invalidate the guarantee. The manufacturer shall not be held liable for any possible indirect damage and/or financial loss caused by the burner.

Ariterm AB reserves the right to decide the method how a possible guarantee repair is carried out. Ariterm AB is not liable for damages occurred after the expiration of the guarantee period, but compensation for such incidents may be agreed upon separately case by case.

## ■ DECLARATION OF CONFORMITY



### VAATIMUSTENMUKAISUUSVAKUUTUS

Valmistaja: ARITERM OY  
Osoite: PL 59, 43101 SAARIJÄRVI  
Laitte: **Biomatic 50 keskuslämmityskattila**

Valmistaja vakuuttaa,  
- että tämän yksilön kattilaosan valmistuksessa on huomioitu Euroopan yhteisön neuvoston painelaitedirektiivin (97/23/EY) olennaiset turvallisuusvaatimukset. Vaatimustenmukaisuuden arviointimenettelyinä on käytetty H - moduulia. (Ilmoitettu laitos 0424)  
- että markkinoille saatettu keskuslämmityskattila on testattu ja hyväksytty Euroopan yhteisön neuvoston direktiivin (92/42/ETY, muutettuna 93/68/ETY) mukaisesti. Direktiivi koskee nestemäisiä ja kaasumaisia polttoaineita käyttävien kuumavesikattiloiden hyötysuhdevaatimuksia.  
- seuraavia standardeja on sovellettu:  
LVD: EN-60335-1  
Konedirektiivi: EN 292-1, EN 292-2  
EMC: EN 55014, EN 610003-3-2, EN 61000-3-3

### DECLARATION OF CONFORMITY - MANUFACTURES DECLARATION

Manufacturer: ARITERM OY  
Address: P.O.BOX 59, FIN-43101 SAARIJÄRVI  
Equipment: **Biomatic 50 central heating boiler**

Manufacturer assures,  
- that in the production of the boiler unit the essential safety requirements of EC council's directive for pressure boilers (97/23/EY) have been complied with. As estimation method of conformity has been used H - module. (Notified body 0424)  
- assures, that this central heating boiler, released in markets, has been tested and approved by EC (European Community) council's directive (92/42/ETY, changed 93/68/ETY). Directive includes efficiency demands for hot water boilers, using liquid or gaseous fuel.  
- following standards have been applied:  
LVD: EN-60335-1  
Machine directive: EN 292-1, EN 292-2  
EMC: EN 55014, EN 610003-3-2, EN 61000-3-3

### FÖRSÄKRAN OM ÖVERENSSTÄMMELSE - TILLVERKAREDEKLARATION

Tillverkare: ARITERM OY  
Address: P.O.BOX 59, FIN-43101 SAARIJÄRVI  
Apparat: **Biomatic 50 centralvärmepanna**

Tillverkare försäkrar,  
- att vid tillverkningen av denna panna har man iakttagit väsentliga säkerhetskrav av EG rådets direktiv för tryckkärl (97/23/EY). Som värderingsmetod av överensstämmelse har använts H - modul. (notified body 0424)  
- att centralvärmepanna, fört ut i marknaden, är testad och godkänd av EG (Europeiska Gemenskapen) rådets direktiv (92/42/ETY, ändrats 93/68/ETY) Direktiv gäller verkningsgradkrav på varmvattenpannor, som använder flytande eller gasformig bränsle.  
- följande harmoniserade standarder har tillämpas:  
LVD: EN-60335-1  
Maskindirektivet: EN 292-1, EN 292-2  
EMC: EN 55014, EN 610003-3-2, EN 61000-3-3

Ariterm Oy

  
Kari Väliaho  
Toimitusjohtaja  
Managing director  
Verkställande direktör

## ■ INSTALLATION PROTOCOL

After installation the burner has to be adjusted. To test every power range, press plus key for 8 seconds in On/Off menu, then can high, low and min modes be test manually. Returning to normal position: Press minus key once.

**ATTENTION! In this function, the burner won't stop when the boiler water reaches desired temperature: boiling risk!**

Flue gas temp. High	CO	O <sub>2</sub>	CO <sub>2</sub>	Air-fuel ratio
Efficiency	Draught (mm)	Fan	Effect %	
Flue gas temp. Low	CO	O <sub>2</sub>	CO <sub>2</sub>	Air-fuel ratio
Efficiency	Draught (mm)	Fan	Effect %	
Flue gas temp. Min	CO	O <sub>2</sub>	CO <sub>2</sub>	Air-fuel ratio
Efficiency	Draught (mm)	Fan	Effect %	

INSTALLER	
Retailer / Installer	_____
Installed by	_____
Inst. date	_____

If these instructions are not followed during installation, operation and maintenance, the obligations of Ariterm AB under the warranty regulations are no longer binding. Ariterm reserves the right to alter any details and specifications without prior notice.



ARITERM SWEDEN AB | Flottljvägen 15  
39241 Kalmar | [www.ariterm.se](http://www.ariterm.se) | 0771-442850

